

BIG C Super Center

Guaranteed Energy Saving

Success Story

Applying Ozone System in Cooling Tower



Datum of Condenser Approach Temperature from BIG C, 5 Branches during 2005-2007

How the electricity saving come from?

Power loss will increase 1.5 % when Condenser Approach Temperature rising 1 F.

(Normally this Condenser Approach Temperature must be kept below 10 F)

Approach Temperature [F]

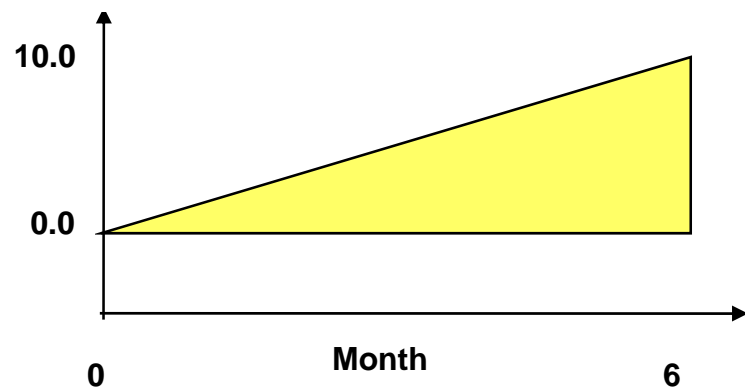

kW / Ton

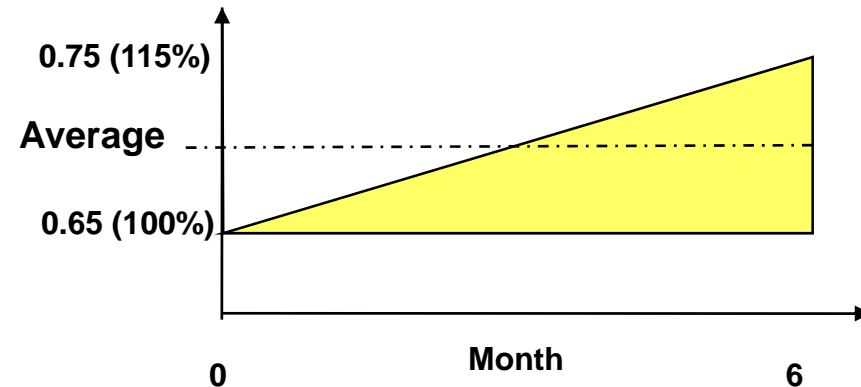

Tube Cleaning during use chemical treatment



Installation of Ozone for Cooling Tower

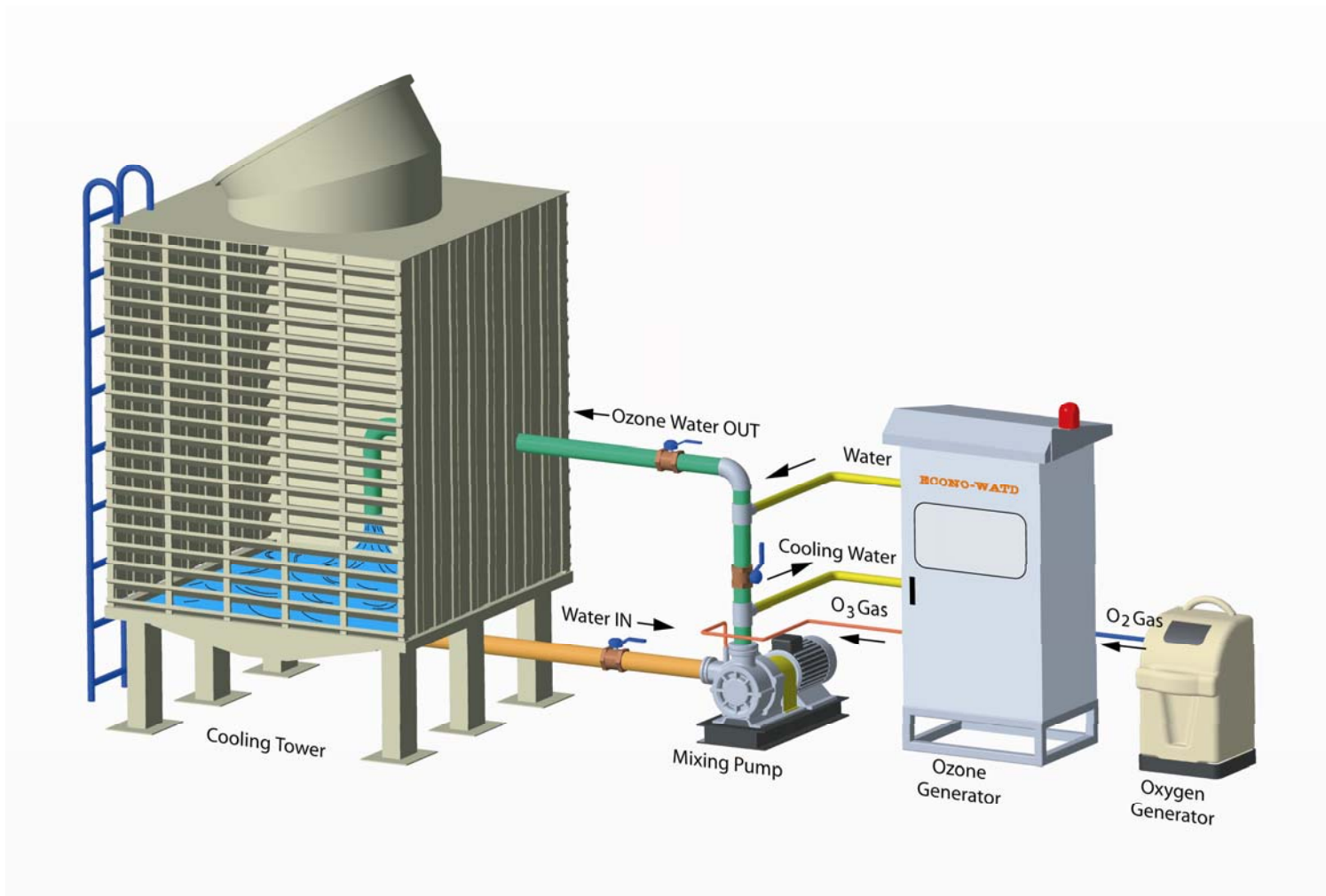

Condenser Approach Temperature

Chiller system

$$\text{Cond.Apppt} = \text{Cond.Satu.Temp.}(T1) - \text{Cond.Wt.Temp.Out.}(T2)$$

Gas
Liquid

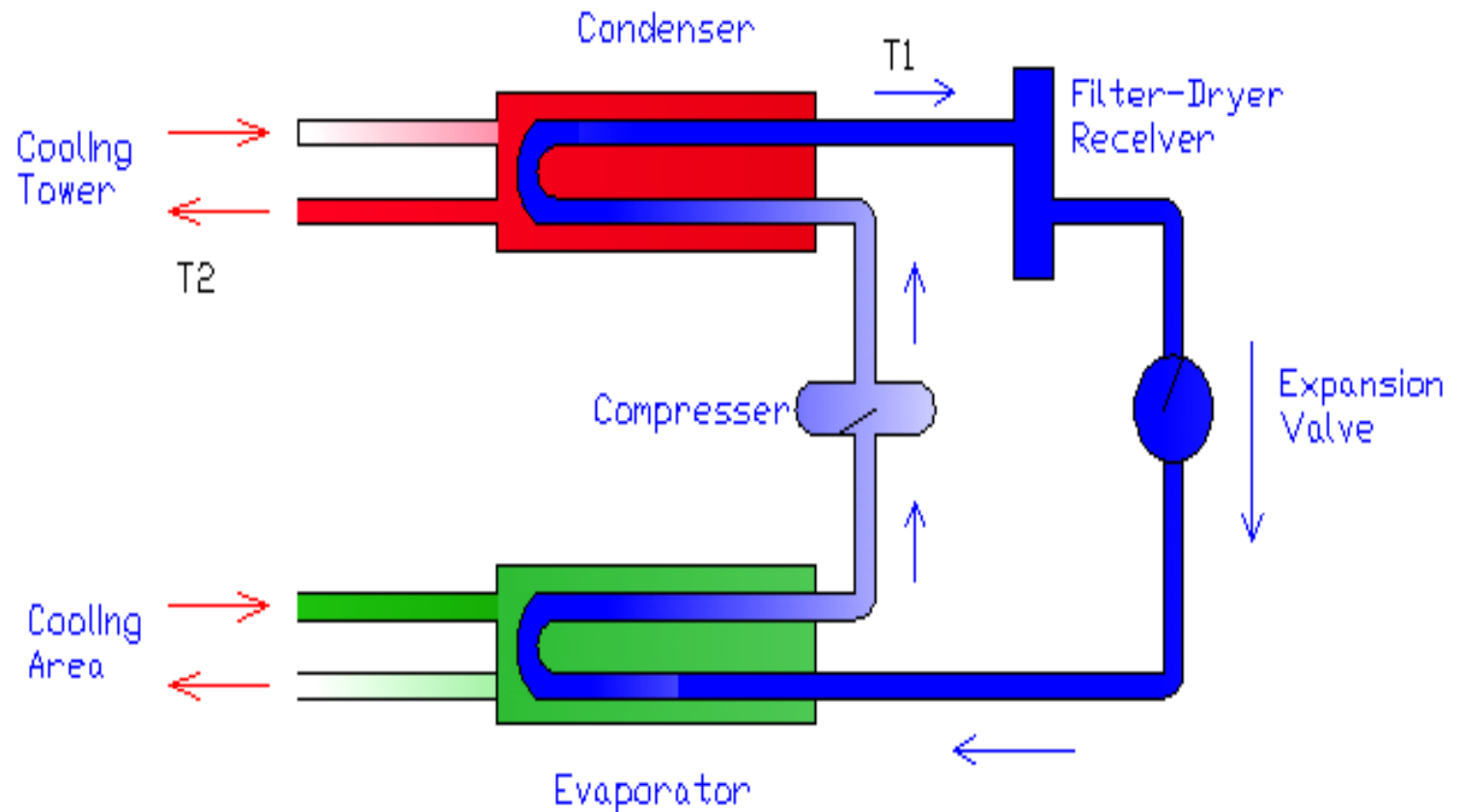

Condenser Approach Temperature during use Chemical in Cooling Tower Big C, Lampang

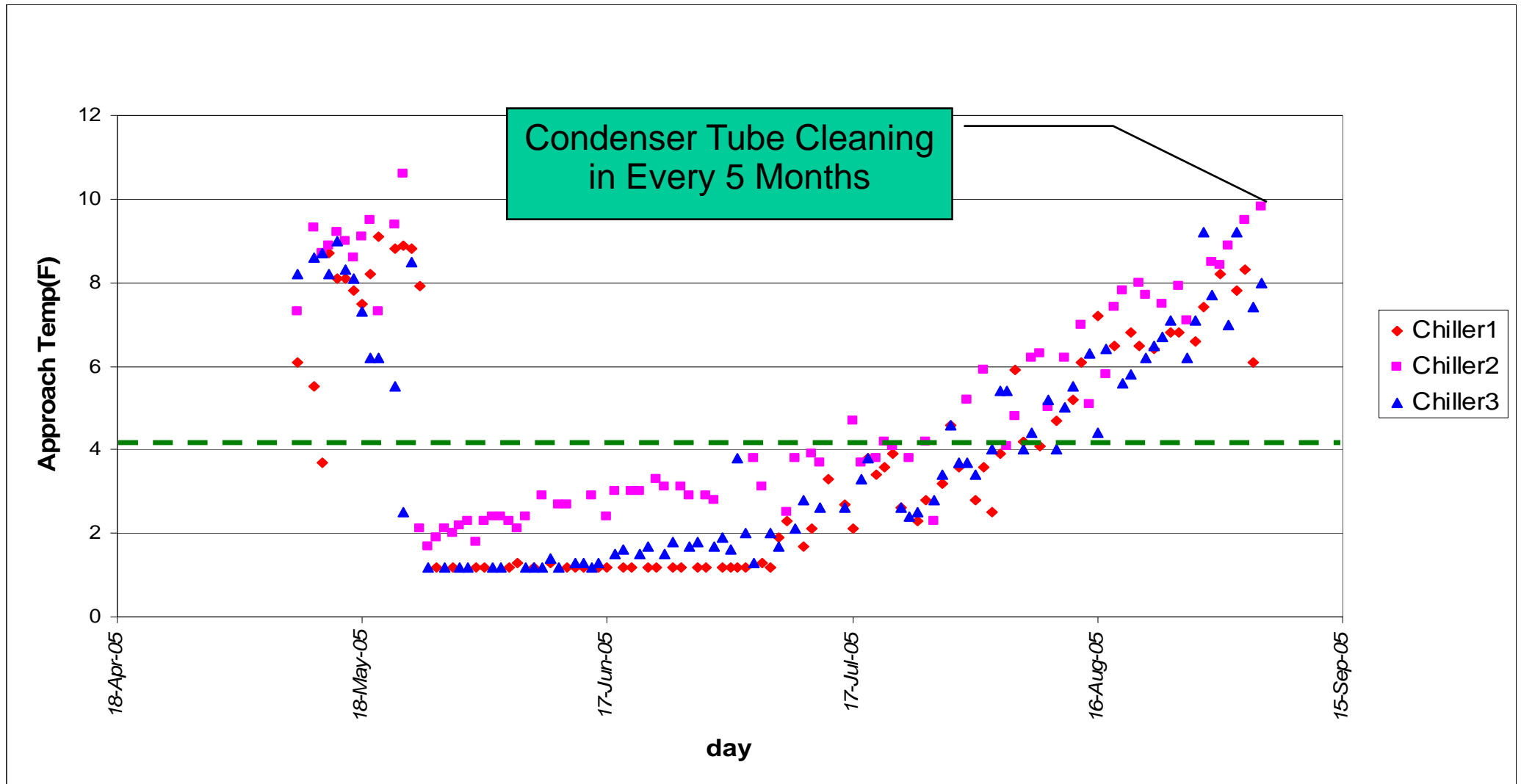

Condenser Approach Temperature during use Ozone in Cooling Tower Big C, Lampang

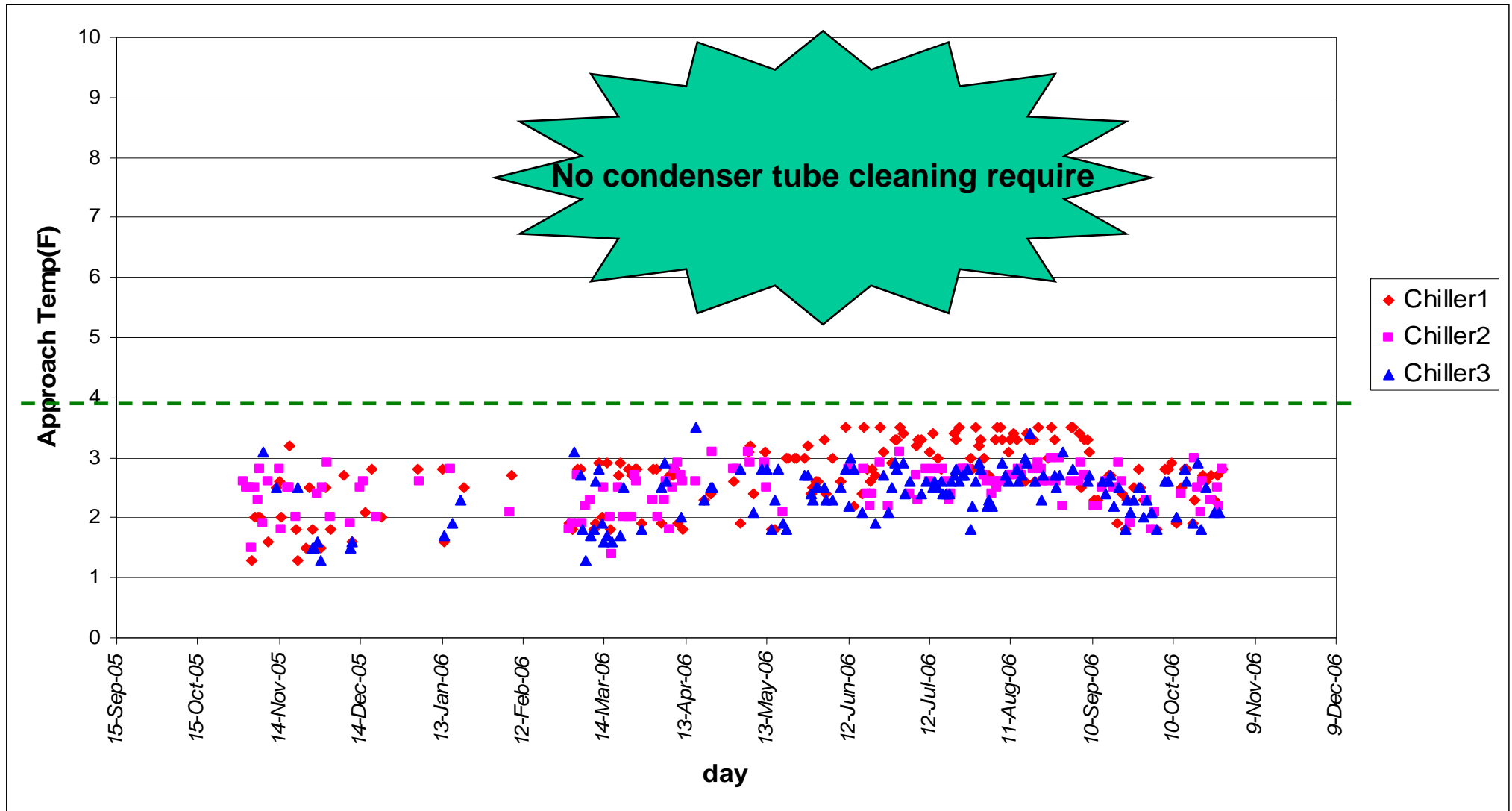

Installation at Big C



Improvement by using Ozone System can save

- Water
- Environment (no chemical)
- Electricity



Condenser Approach Temperature of Big C, Lampang

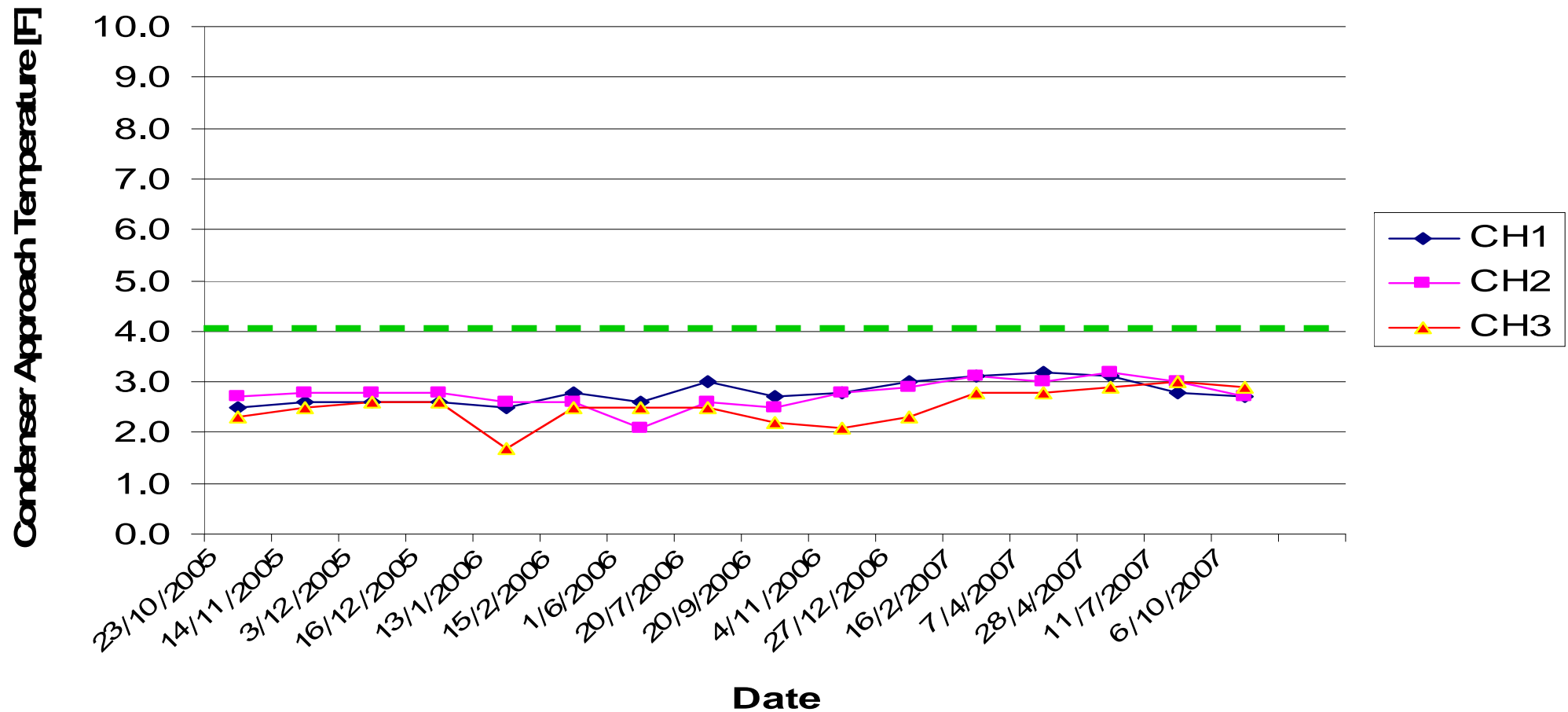

Condenser Approach Temperature of Big C, Chiangmai

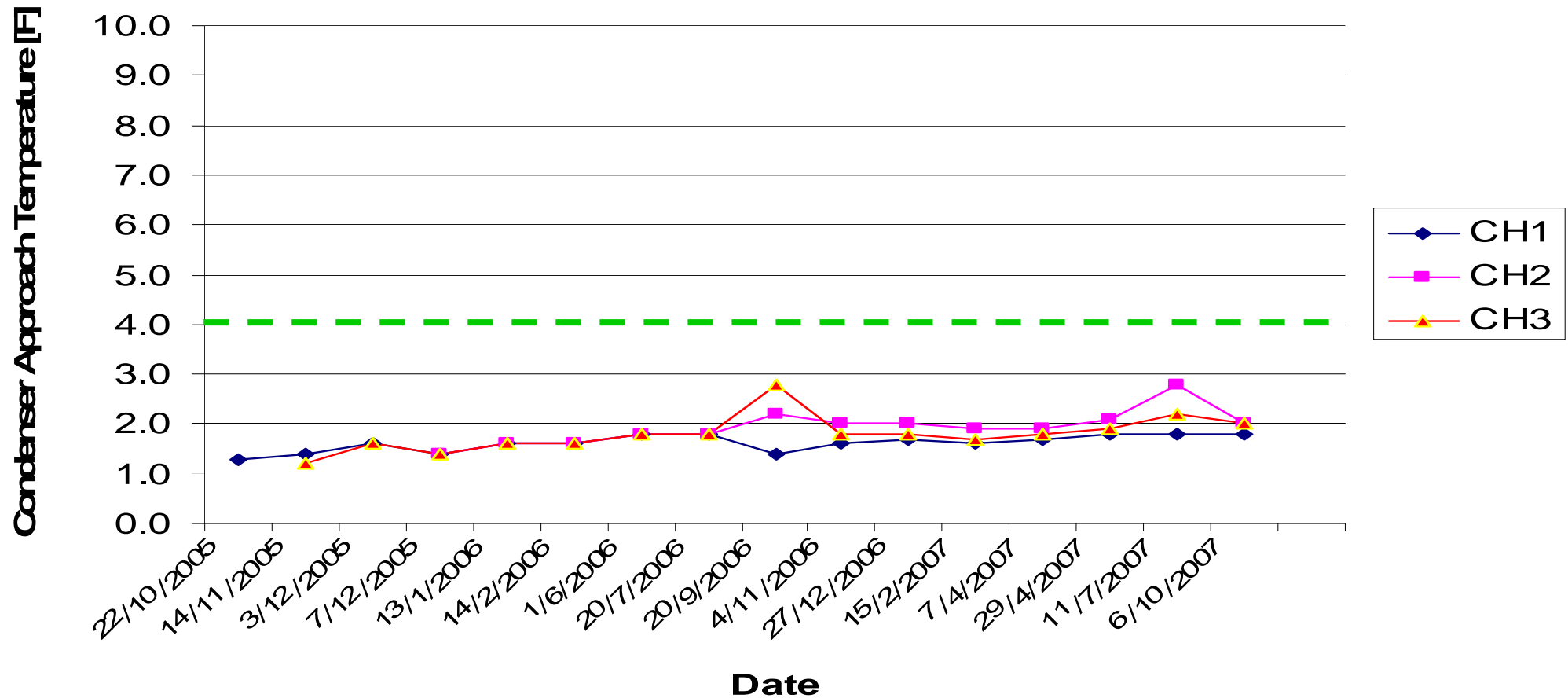

Condenser Approach Temperature of Big C, Khonkaen

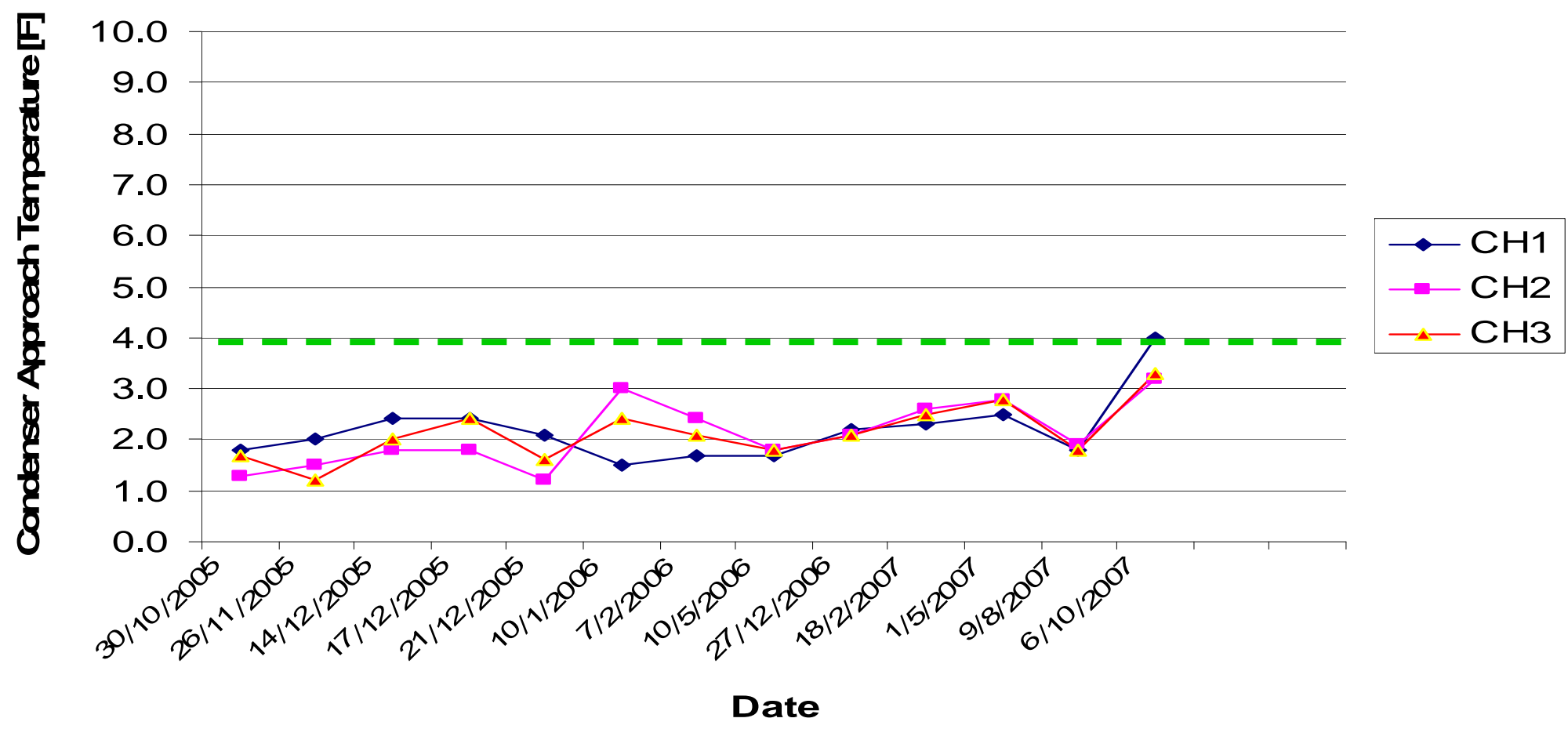

Condenser Approach Temperature of Big C, Udonthani

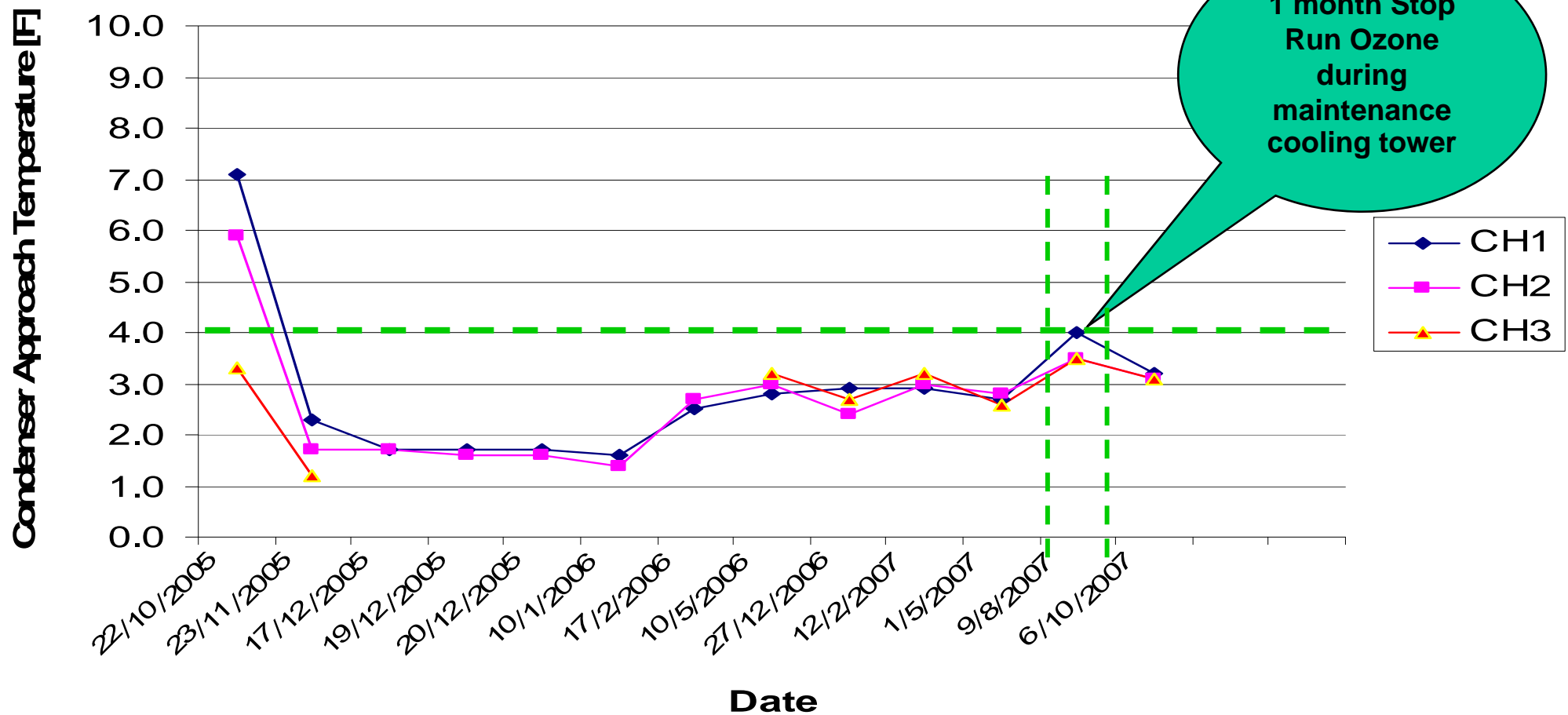

Condenser Approach Temperature of Big C, Phuket

